



## Optimizing Bolted Joint Geometry for Fatigue Resistance

Integrated Systems Research, Inc  
May, 2008

Tech Brief 080501F

### Abstract

Bolted joint separation is greatly facilitated when the loading on the connection is eccentric to the fasteners. Such joint behavior increases the potential for bolt fatigue, primarily due to the bending moment carried by the fasteners as lift off occurs. Most conventional flange designs create some amount of eccentric loading on the fasteners.

This tech brief addresses the behavior of eccentrically loaded bolted connections by evaluating the relative benefits that various joint features have on increasing the resistance to separation. The results of a response surface analysis of a conventional cylindrical flange design is presented. The results are coalesced into a methodology which an engineer can employ to efficiently explore options in the preliminary design phase. As with any critical bolted joint, the preliminary design should be finalized with a finite element evaluation.

### Bolted Joint Behavior

The primary characteristic of a successfully bolted joint is the maintenance of flange compression under service loads. As long as the clamped joint remains in compression the majority of the externally applied load will be carried by the flange and not the bolt. After preloading, the strain range carried by the bolt and flange is equal, as they act as springs in parallel. Since the flange is typically stiffer than the bolt, the majority of the applied load is carried by the flange as its compressive state is decreased. Once the joint is taken out of compression, however, the flange and bolt no longer act as springs in parallel and the external load will be carried entirely by the bolt. Maintaining the joint compression, then is the key parameter in shielding the bolt from fatigue loading.

The relationships between the loads carried by the joint and bolt due to external loading are given below:

$$F_b = P + \frac{k_b}{k_b + k_j} F_e \quad \text{Eq. 1.0}$$

$$F_j = P - \frac{k_j}{k_b + k_j} F_e \quad \text{Eq. 2.0}$$

where

$F_b$  = Load carried by bolt (lbs)  
 $F_j$  = Load carried by joint (lbs)  
 $F_e$  = External load (lbs)  
 $P$  = Preload (lbs)  
 $k_b$  = bolt stiffness (lbs/in)  
 $k_j$  = Joint stiffness (lbs/in)

Notice, from equation 1.0, when  $k_j \gg k_b$  the bolt loading from external loads is virtually zero as long as the joint remains in compression. For this stiffness condition, however, the joint will come out of compression when the external load reaches the preload value (e.g., reference equation 2.0 and set  $F_j = 0.0$ ). For conditions where  $k_j > k_b$  the bolt will carry a portion of the

external load, but it also requires an external load greater than the preload for the joint to come out of compression.

This is the essential feature of the design problem, from a fatigue standpoint. The flange or joint needs to have a high enough stiffness relative to the bolt that it shields the bolt from external loads, but not so stiff that the compression of the joint is lost prematurely. This is especially true when the external load creates prying action on the bolt.

### Fatigue Considerations in Axially Loaded Joints

Under axial loading, in contrast to shear loading, the location most susceptible to fatigue is one turn in from the bearing face of the nut. It is typically at this location where the load transfer between the bolt and nut is maximum. The type of thread both in terms of form and manufacturing process significantly influences the fatigue resistance of the fastener.

The UNJ thread form increases the thread root radius compared to other UN threads, enhancing the fatigue resistance of the fastener. Rolled versus machined threads also increase fatigue resistance, especially as the tensile strength of the bolt material increases. One of the reasons, among others, for rolled threads providing greatly improved fatigue properties is the elimination of the decarburized surface. This decarburized layer is typically 0.001 to .002 inches thick. Eliminating this potential crack initiation layer greatly increases fatigue resistance.<sup>1</sup>

Increasing the strength of the bolt material, typically does not provide the benefits one would expect based on increased mechanical properties. One reason for this is the effective  $K_t$  (e.g.,  $K_t$ ) in the thread root tends to be higher with alloys having higher strength values and lower ductility. Additionally, higher strength alloys tend to be more susceptible to intergranular attacks such as stress corrosion and hydrogen embrittlement.

### Bolted Flange Geometry and Load Path

As with any structural system, the fatigue resistance of a bolted joint is principally governed by three parameters: loads, materials, and geometry. Of the three, materials and geometry are typically the two parameters an engineer has the most control over in the design process. Of these two, geometry is by far the parameter that can provide the most leverage in creating a fatigue resistant design.<sup>2</sup>

Design constraints seldom allow bolted joints to be designed such that the line of action of externally applied loads act along the centerline of the fasteners. For joints intended to carry high alternating loads, however, this strategy should be considered when possible. The approach typically requires pockets to be machined around the joint perimeter allowing the fasteners to join the flanges at the mid-plane of the load carrying membranes of the structural load path.

In a conventional flange design, the offset of the applied load with respect to the fasteners creates a prying action on the joint. The moment equilibration, in the joint, is statically indeterminate.

<sup>1</sup> ASM Handbook Vol 19 Fatigue and Fracture, p.288

<sup>2</sup> Reference Fatigue of Mechanically Fastened Joint, Harold Reemsnyder, AMS Handbook Vol 19 p. 297. This is also the case with as welded joints. For information on a short course covering weld fatigue click on the link below [Weld Fatigue Short Course](#)

This in part, though not exclusively, is due to the flange being a ring and thus able to carry an internal radial moment. A sector of such a flange design is shown below.

The prying action, not only increases the ease in which the flange will come out of compression below the bolt, but also requires that moment equilibration be provided internally by the joint. For the bolt to maintain the flange in compression there can be no relative slope between the joint faces underneath the bolt head.

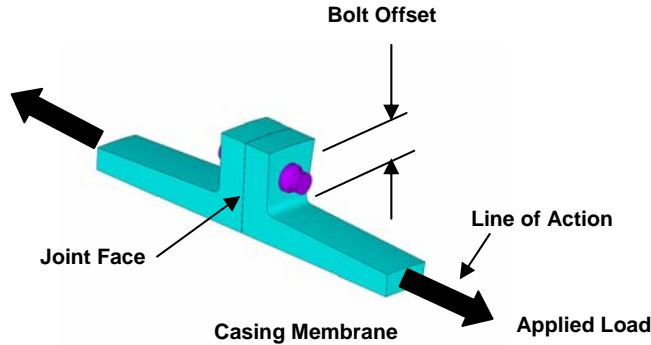

**Figure 1 - Typical Flange Construction Sector**

If the internal moment capability of the flange is temporarily relaxed, then the means by which the equilibrating moment can be developed is either by a heel-toe reaction of the flanges and bolt, a local bending moment carried by the bolt itself, or a combination of both. If initial joint separation, referred to as lift off, were primarily controlled by a heel-toe reaction of the flange and bolt, then the flange height and thickness would be expected to provide significant leverage in designing against initial joint separation. On the other hand, if the moment equilibration is solely provided by the bolt in bending, then the moment carried by the bolt would be expected to develop rapidly once lift off is initiated. Neither one of these scenarios are predicted by finite element modeling of eccentric joints. The actual equilibration is a combination of both the heel-toe and bolt moment mechanisms that are compatible with the deflection state of the joint. An approach for estimating the initiation of lift off from the combined interaction of these mechanisms is outlined in the section entitled *Estimating Initiation of Joint Lift Off*.

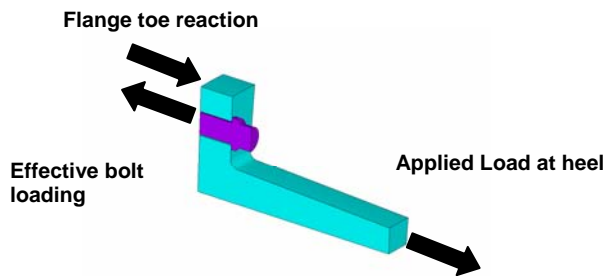

**Figure 2 - Heel-Toe Equilibration Mechanism**

## Bolt Preload Considerations

Since maintaining the flange in compression is the central task in resisting bolt fatigue, it comes as no surprise that proper preload is essential in the implementation of a well designed joint. Two basic approaches are available to create the desired joint preload. The first are load controlled methods and second are strain controlled.

### Load Control Tightening Methods

For larger bolts, hydraulic tensioners are often employed to preload a joint. The tensioner seats against the flange and develops the specified tensile load in the bolt. Once the desired load has been developed, which equals the preload and an additional amount for relaxation, the nut is run down to the flange and the hydraulic load relieved. The positive aspect of this methodology is its inherent repeatability. Since friction between the fastener and flange and fastener and nut are not involved in developing the preload, this approach provides results with significantly less scatter than the torque-tension method.

The torque-tension approach, however, is by far the most common method employed to preload bolts. The primary reasons are cost and ease of execution. The downside to this approach is the variation that occurs in the actual developed preload as the applied torque is converted into a bolt tensile load.

It is estimated that 50 percent of the torque is used to overcome the friction between the bolt head and flange, 40 percent to overcome thread friction and only 10 percent is actually used in developing the tensile load.<sup>3</sup> The common empirical torque-preload relationship is given below. The coefficient K has been empirically derived and is estimated to be 0.20 for non-plated bolts in their as-received condition. Zinc and hot-dip galvanized plating tends to roughen the surfaces increasing the value of K while cadmium tends to increase lubricity decreasing the value of the coefficient.

$$T = KDP \quad \text{Eq. 3.0}$$

where

- T = torque (lbs-in)
- K = torque coefficient (dimensionless)
- D = nominal fastener diameter (inches)
- P = bolt tensile load (lbs)

Due to the scatter associated with load controlled preload techniques, the preload specification is typically based on 75 percent of the bolt proof strength rather than preloading to the bolt's yield strength. In addition to the preload scatter, it should also be kept in mind that joints tend to relax rapidly after initial preloading. Relaxation as much as 10 percent is not uncommon. This relaxation is primarily due to rough spots in the mating surfaces. This is one reason for an engineer to consider carefully the specifications of surface finish and parallelism of joints as well as the class of threads in critical joint applications.

### Tightening Methods with Elongation Specification

Inducing preload by measuring the change in the overall length of the bolt is one of the most accurate means of clamping a joint. If the desired preload load approaches the yield strength of the bolt, this approach provides a means of accurately controlling the load developed in the fastener. The downside to this methodology is the cost and accessibility to the equipment necessary to implement the technique.

Another strain controlled method, which is used extensively, is the turn-of-nut. This approach requires that a snug condition exists prior to turning the nut a specified amount to obtain the desired preload. Obviously, the starting point associated with

<sup>3</sup> Industrial Fastener Institute, Fastener Standards 6<sup>th</sup> Ed, M-64

the snug condition is key to obtaining repeatable results. Parallelism and surface quality are once again important parameters to control in implementing this preload strategy. Recommended nut rotation as a function of bolt size and length can be obtained from the Research Council on Structural Connections.<sup>4</sup> [RCSC Specification Ref Section 8.2.1](#)

### Response Surface For Eccentrically Loaded Joint

The response surface analysis evaluated the influence of bolt spacing, flange thickness, flange height, and bolt size on the resistance to joint separation. The design of experiments held the bolt circle and case mid-plane constant (e.g., the offset of the line of action to the bolt). The conventional flange design is shown below.

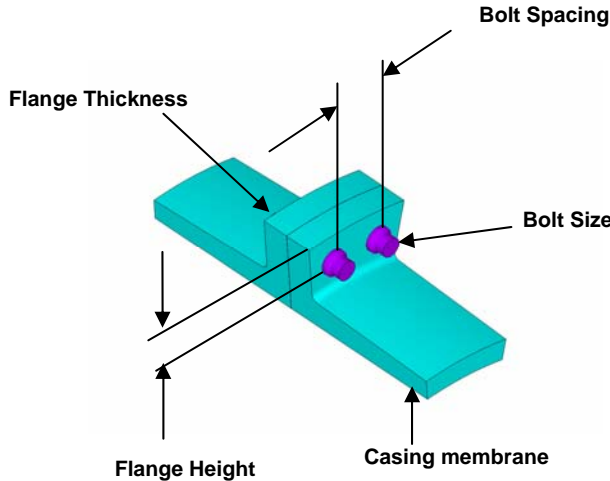

Figure 3 - Response Surface Parameters

The design parameters of bolt spacing, flange thickness, and flange height were adjusted as characteristics dimensions relative to the bolt size (e.g., scaled with the bolt sizes). The reason for setting up the analysis in this manner is that best practice dictates that the regions of flange compression overlap, creating a fully effective joint. Changing these parameters in the analysis as a function of bolt size ensures that the analysis design space represents good design practice. The preload used in the study assumed SAE Grade 5 bolts.

Table 1 - Response Surface Variables

Ratios	Joint Variables	Variable States		
		-1	0	1
	Bolt Size	0.25	0.3125	0.375
L/D	Bolt Spacing	3.00	3.50	4.00
T/D	Flange Thickness	1.25	1.50	1.75
R/D	Flange Height	1.50	2.00	2.50

Bolt Sizes (Inches)

Ratio to bolt size

The 3 level Box-Behnken design of experiments required 27 runs. The point of lift off initiation was determined by the moment carried by the bolt head. The flange faces are typically separate up to the point of the bolt centerline when the bolt bending moment begins to develop as shown in Figure 4.

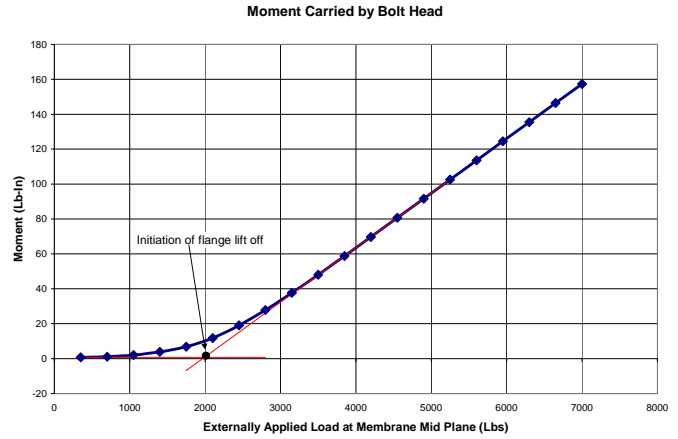

Figure 4 - Lift Off Initiation Calculation

### Response Surface Results

The results of the response surface analysis are based on the maximum bending moment the casing can carry with initiation of lift off occurring at the highest loaded bolt. The relationship to find the peak membrane load for the highest loaded bolt is provided below:

$$F_{peak} = \frac{2M}{RN} \quad \text{Eq. 4.0}$$

where

- M = Moment carried by the case (lb-in)
- R = Mid plane case radius (in)
- N = Number of bolts

The maximum case bending moment was found by using equation 4.0 and solving for M. The  $F_{peak}$  value was obtained from the lift off calculations for each of the 27 runs.

Figure 5, provides the response surface as a function of bolt size and spacing. As one would intuitively expect, the moment capacity of the joint is a strong function of the bolt size which decreases as the spacing between the bolts increase.

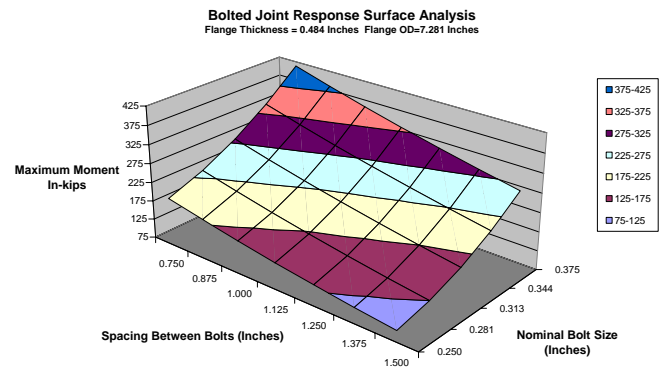

Figure 5 - Response Surface Results

The joint moment capacity, however, is a relatively weak function of the flange height above the bolt centerline. The objective function in this case is maximizing the resistance to initial lift off, not capacity under ultimate loading conditions. The results indicate that extending the flange height to create a more

<sup>4</sup> Ibid, M-66

efficient lever arm against bolt prying is not a productive strategy when addressing initial flange lift off.

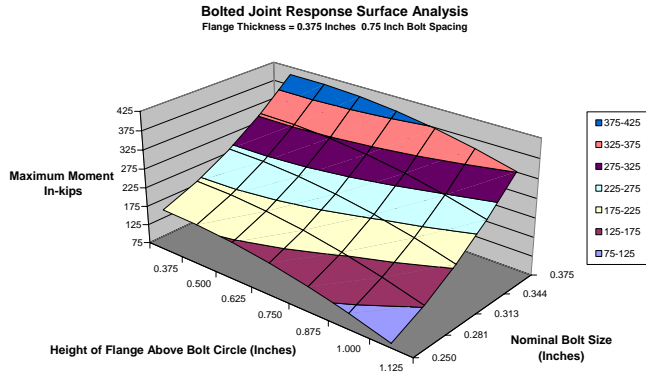

Figure 6 - Response Surface Results

To further investigate this behavior, a flange thickness/height trade study was undertaken. Nine runs were included in this study. The first three employed a 0.25 inch diameter bolt preloaded to 3275 lbs with the flange thicknesses varying from 0.375 to 0.625 inches. The flange height above the bolt circle was equal to the flange thickness. The next three runs employed a 0.312 inch diameter bolt with flange thicknesses varying from 0.500 to 0.750 inches. The bolt preload was 5220 lbs. The relationship between flange height and thickness was the same as the one used in runs 1 through 3. A 0.375 inch diameter bolt was modeled in the last three runs with the flange thicknesses varying from 0.625 to 0.875 inches. Once again the same flange height/thickness relationship used as in the other runs. The bolt preload was 7900 lbs.

As seen from the results provided in Figure 7, the thickness and height of the flange are secondary parameters in regards to flange lift off. It should be kept in mind, however, that the amount of preload relaxation is reduced the longer the bolt (e.g., the thicker the flange) and benefits for a joint to survive under ultimate loading conditions can be gained by increasing the flange height.

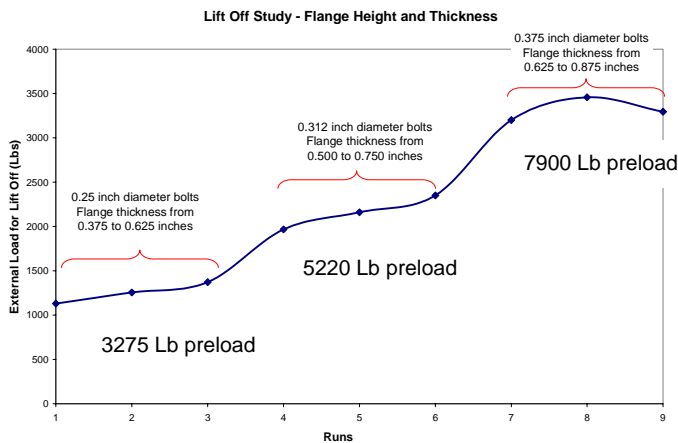

Figure 7 - Separate Flange Thickness/Height Study

### Estimating Initiation of Joint Lift Off

The results of the response surface analysis indicate that within the design space evaluated, flange thickness and height are not

strong variables for resisting initial flange lift off. In estimating the applied load required for this condition, the equilibrating moment can be either estimated by a heel-toe or bolt bending assumption.

#### Estimating Peak Load with Heel-Toe Assumption

The heel-toe estimation assumes that the toe reaction occurs at the maximum extent of the compression frustum carried by the flange. In the response surface analysis, the frustum cone angle observed in the finite element results was approximately 30 degrees. The location of the toe reaction is then estimated by equation 5.0.

$$R = (T + D)\tan(30) \quad \text{Eq. 5.0}$$

where

- R = Toe reaction above bolt centerline (In)
- T = Flange thickness (In)
- D = Nominal Bolt Dia (In) = Height of Bolt Head

The membrane mid-plane radius is at 5.8125 inches and the bolt circle at 6.625 inches. The stiffness ratio between the joint and bolt is assumed to be 3:1. This is typically a reasonable assumption for joints that are made of alloys having the similar physical properties as the bolt. The applied external load required to create lift off is given below.

$$F_{peak} = \frac{4PR}{3(R + Offset)} \quad \text{Eq. 6.0}$$

where

- P = Bolt Preload (Lbs)
- Offset = Distance between bolt and case mid-plane (In)

#### Estimating Peak Load with Bolt Moment Assumption

The other approach, to estimating the maximum external load for joint lift off, is to assume that the moment, created by the line of action offset, is equilibrated by the bolt through a toe reaction under bolt head. The moment carried by the bolt can be calculated from the case provided in Roark and Young for a circular plate with a fixed outer edge and guided inner annulus. The effective bolt load is then estimated by taking the moment per bolt and assuming that the effective axial line of action for the equilibrating toe reaction acts through the upper half of the bolt shank. That distance from the bolt centerline to this assumed line of equilibrating action is the bolt diameter divided by  $\pi$ . Figure 8 references the case cited above.

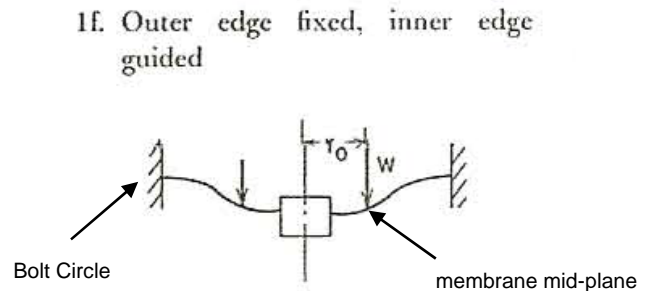

Figure 8<sup>5</sup>

<sup>5</sup> Formulas for Stress and Strain, 5th Ed., McGraw Hill, p. 336

Employing this case makes the moment carried at the bolt circle independent of the flange thickness, which as demonstrated by the results provided in Figure 7 appears to be a reasonable assumption.

Figure 9 provides the comparisons of the Heel-toe and Bolt moment estimates to the finite element model results. Note that the averages between the two assumptions are in good agreement with the finite element results and the scatter between the two estimates increases with bolt size.

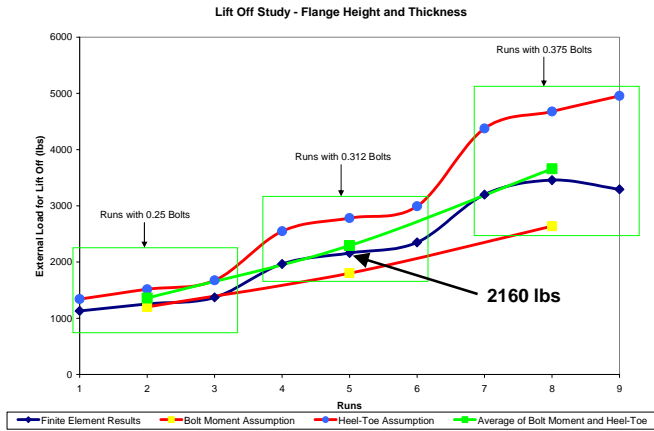

Figure 9

**Optimizing Joint Geometry for Fatigue Loading**

The response surface and subsequent trade study indicate that flange thickness and height are weak design parameters for increasing a joint's margin against lift off. In fact, as indicating in the opening section entitled *Bolted Joint Behavior*, increasing the flange stiffness can be detrimental. Figure 10, is a modification of the Run 5 flange in the trade study shown in Figure 9. As evidenced from the scalloped ribs, the flange stiffness was significantly increased. The result, however was lift off occurring at an applied load of 1777 lbs rather than 2160 lbs. Stiffening the flange increased the prying efficiency on the bolt, lowering the applied load required for lift off.

Significantly increasing flange stiffness while maintaining the line of action offset decreased lift off capacity by 18%

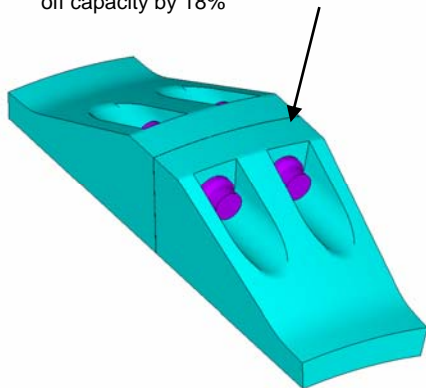

Figure 10 - Stiffened Run 5 Joint

Besides bolt size, the parameter that provides the most effective means of increasing a joint's resistance to lift off is to decrease the offset between the bolt circle and line of action of the applied

load. Decreasing the line of action offset while maintaining a balanced stiffness ratio between the joint and bolt will drive the joint design towards maximum lift off resistance for a given bolt size. Figure 11 provides the predicted lift off loads as a function of the line of action offset to the bolt. The offset was reduced by maintaining the bolt circle diameter and increasing the membrane case radius.

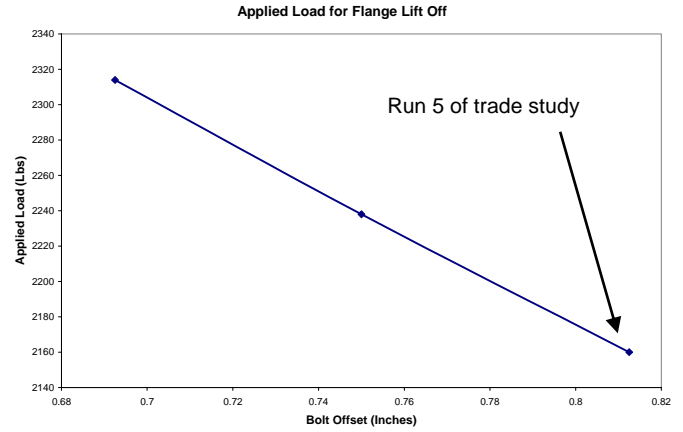

Figure 11 - Conventional Flange

The performance of the joint was increased even further by modifying the joint geometry so that the bolt offset was decreased to 0.500 inches. This low profile flange geometry, shown in Figure 12, allows the case to remain at the same radius and the flange weight to remain approximately the same as the baseline design while increasing its lift off resistance by 19 percent compared to Run 5 (e.g., lift off load predicted to be 2571 lbs). In addition to optimizing weight, the low profile flange also created a good balance between flange and bolt stiffness. The result of this stiffness balance is that the bolt moment for the low profile flange is lower than the conventional flange even when lift off occurs.

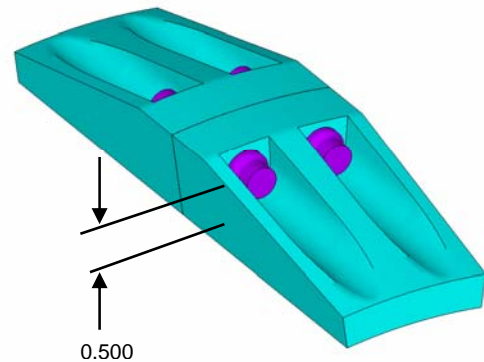

Figure 12 - Low Profile Flange

The bolt bending moment is the loading factor contributing the most to fatigue of the bolt. This is due to the section modulus of the thread root being significantly lower in value than the bolt's tensile area. Tables 2 and 3 provides the nominal

alternating stress values for both the conventional and low profile flanges

**Table 2 - Stress Range at Conventional Flange Lift Off**

Design	Tensile Load Range Lbs	Bending Moment Range Lbs In	Tensile Stress Range ksi	Bending Stress Range ksi	Total Stress Range ksi
Run 5 (Conventional)	200.0	7.4	3.8	4.4	8.2
Low Profile Flange	114.8	8.1	2.2	4.8	7.0

**Table 3 - Stress Range at Low Profile Flange Lift Off**

Design	Tensile Load Range Lbs	Bending Moment Range Lbs In	Tensile Stress Range ksi	Bending Stress Range ksi	Total Stress Range ksi
Run 5 (Conventional)	386.0	12.86	7.4	7.6	15.0
Low Profile Flange	177.4	11.0	3.4	6.5	9.9

The fatigue limit for a SAE Grade 5 bolt is 57 ksi.<sup>6</sup> This value would be adjusted for statistical scatter and mean stress. The  $K_f$  applied to the nominal thread root stresses would be between 2.5 to 3.4.

As seen from Tables 2 and 3, the low profile flange outperforms the conventional flange, not only due to the reduction in the line of action offset but due to the flange not being able to pry as effectively on the bolt.

Proper preload is essential for the implementation of a well design joint. Becoming familiar with the pros and cons of preload options is key in developing a successful preload specification for critically loaded joints.

For further information regarding flange design strategies and considerations for bolted joints a short course is available entitled *Practical Design Considerations for Bolted Joints*. For more information regarding this course see [Practical Design Considerations for Bolted Joints](#)

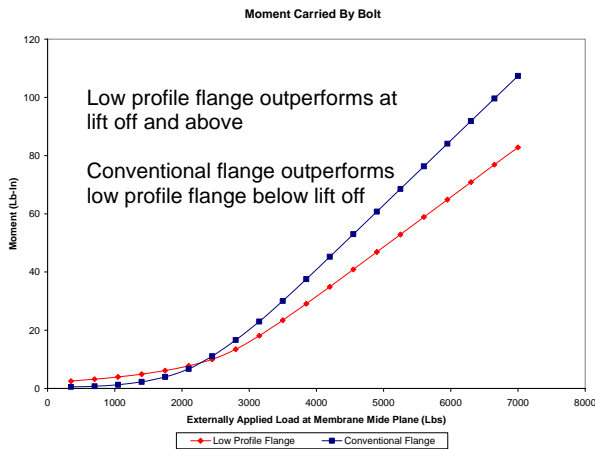

**Figure 12 - Performance Comparison**

**Summary**

The essence of the bolted joint design problem is minimizing the line action offset of the external load with respect to the bolts and balancing the stiffness of the joint and bolt to maximize the external load required for joint lift off.

The average of the heel-toe and bolt moment methods provide good correlation with finite element results. These results are not surprising considering the actual equilibration mechanism is a combination of both. The approach of averaging both estimates can be used to efficiently evaluate geometry alternatives prior to finalizing a joint design with a finite element model.

<sup>6</sup> Mechanical Engineering Design, 4th Edition, Shigley and Mitchell, McGraw Hill p.385